

# BALL VALVE

KHD-2F-FK-XC/RPTFE  
With flanges, full bore  
ANSI-class 150, 1/2" - 12"

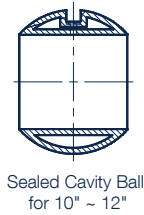
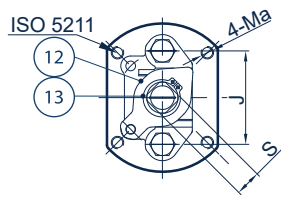
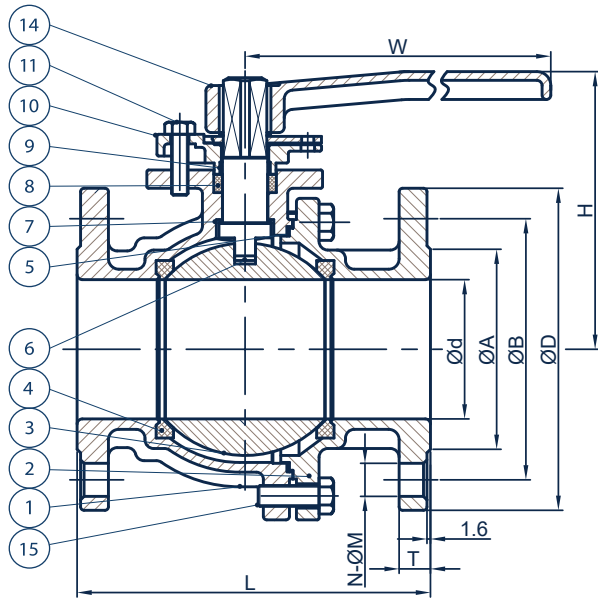

## PARTS

No.	Part	Material
1	Body	CF / CF8M / WCB
2	Cap	CF / CF8M / WCB
3	Ball	CF / CF8M
4	Ball seat	PTFE
5	Body seal	PTFE
6	Stem	SUS 304 / SUS 316
7	Thrust washer	TFM4215
8	Stem packing	PTFE
9	Stem bushing	PTFE
10	Gland	CF8
11	Gland bolt	SUS 304 / Carbon steel
12	Locking device	SUS 304
13	Snap ring	SUS 304
14	Handle	FCD
15	Body bolt	SUS 304 / Carbon steel

## DIMENSIONS AND WEIGHTS

Size		d	L	H	T	S	A	B	D	W	J	Ma	ISO 5211	N-ØM
IN	DN													
1/2"	15	15	140	92	14,3	12	35	66,5	95	160	50	M5	F04	4-Ø16
3/4"	20	20	152	98	15,9	12	43	82,5	117	160	50	M5	F04	4-Ø19
1"	25	25	165	103	17,5	12	51	89	124	160	50	M6	F05	4-Ø19
1 1/4"	32	32	178	107	19,1	12	64	98,5	133	160	50	M6	F05	4-Ø19
1 1/2"	40	40	190	112	20,7	17	73	114,5	156	230	62	M8	F07	4-Ø22
2"	50	50	216	122	22,3	17	92	127	165	230	62	M8	F07	8-Ø19
2 1/2"	65	65	241	151	25,4	21	105	149	190	350	75	M8	F07	8-Ø22
3"	80	80	283	161	28,6	21	127	168	210	350	75	M10	F10	8-Ø19
4"	100	100	305	175	31,8	21	157	200	254	350	75	M10	F10	8-Ø19
6"	150	150	403	47	36,6	21	216	270	318	750	89	M12	F12	12-Ø22
8"	200	200	502	305	41,3	32	270	330	381	1000	100	M12	F12	12-Ø25
10"	250	250	568	351	47,7	32	324	387	444	1000	100	M16	F14	16-Ø29
12"	300	300	648	389	50,8	32	381	451	521	1000	100	M16	F14	16-Ø32

## STANDARDS

- » Design according to ASME B16.34
- » Face to face according to ASME B16.10
- » Flange end dimensions according to ASME B16.5
- » Inspection & test according to API 598